

BASIC, PREMIUM, ELITE

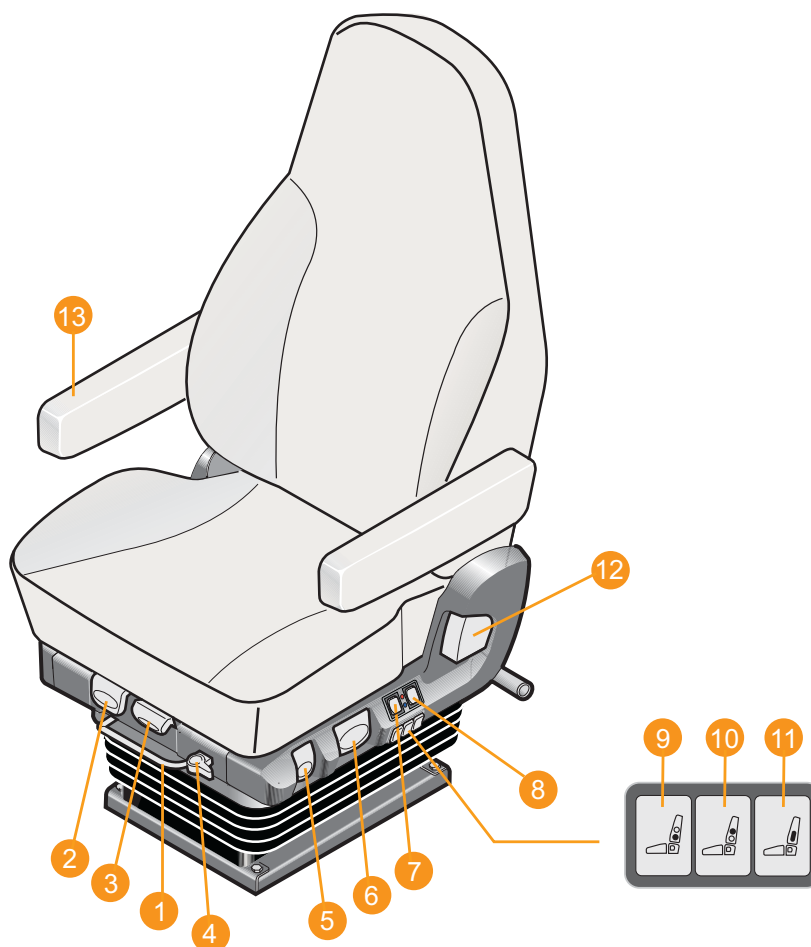



	Warning Notes.....	Page 3
1	Horizontal Slides.....	Page 5
2	Tilt Adjustment.....	Page 5
3	Seat Cushion Adjustment.....	Page 6
4	Horizontal Isolator.....	Page 6
5	Damper Adjustment.....	Page 6
6	Height Adjustment.....	Page 7
7	Heating and Ventilation System.....	Page 7
8	Level switch of Heating and Ventilation System.....	Page 7
9 10 11	Lumbar Support/ Side Bolster Support.....	Page 8
12	Backrest Adjustment.....	Page 9
13	Armrest.....	Page 9

General notes



Please carefully read these operation instructions before using the ISRI seat. Make sure to follow all instructions and become familiar with the features of the seat.

The instructions must always be readily available for the driver. For the latest warnings issued, please visit: <http://www.isriusa.com/com/service-center/seatingsystems/download.html>

In the case of selling the truck or seat, the first owner is obligated to pass on this manual.



WARNING

Keep hands, tools, and other objects away from the scissor points under the seats. Failure to do so could cause personal injury.

Liability and Warranty

Failure to follow this instruction manual may result in liability, warranty and national vehicle's type approval loss. Manufacturer assumes no liability or warranty for consequent damages should this manual not be adhered to. Failure to comply with the instructions provided may cause serious or fatal injury to yourself and others.

Attention to detail is imperative in order to adjust the seat to an optimal position for your body. Make sure that all the seat functions work properly and that the seat is not defective. An incorrectly set seat or a wrong seating posture may have a negative impact on the ergonomics, driver's body, and operating capacity of the vehicle. Improper settings of the seat may affect the ability to properly operate the vehicle in a safe manner to prevent accidents that may cause serious or fatal accidents.

The seat must be installed, repaired or maintained by qualified specialists. Maintenance shall be performed by experienced professionals only. At time of installation, the regulations of the country of installation, the installation instructions and operating manual terms, conditions and instructions of the vehicle manufacturer must be followed.

Operating Instructions

- Taking proper and gentle care of your seat is imperative for a long lasting lifetime.
- For your safety, and for the safety of other drivers, the seat can only be adjusted while seated, when the vehicle is fully stopped, and while the hand brake is pulled.
- Before you start driving, the seat must be adjusted to an optimal position for your body and the correct seating posture must be taken, particularly when switching vehicles.
- Never use a damaged or faulty seat.
- In case of malfunction or defective parts an authorized dealership has to be immediately visited in order to check, repair, or exchange the seat or its parts.
- The following mechanisms must lock audibly into position; horizontal slides, backrest recline, seat cushion length, and tilt. Pull the levers completely during the whole duration of seat adjustment, otherwise improper use could damage parts over time. The control levers must return to their normal position after adjustments are made.
- Don't operate several control elements at the same time.
- Make sure to always use your seat belt for the whole duration of your drive. Never belt in more than one person per seat belt. Do not fasten anything on the passenger seat other than the person sitting in it or an accredited child seat.
- Keep hands away from the adjustment mechanism and suspension system. Failure to follow this may cause injury to your hand and fingers.
- Making changes to the seat are strictly prohibited. Fulfilment of applicable regulations for vehicle's safety features and type approval might expire.
- Do not place anything - like for example jackets, blankets, pillows or bags - over a seat, that has the heating or ventilation feature. In this case it is also not allowed to use protective covers.
- The seat shall not be used as method of ascent while entering the vehicle. Standing on the seat is not permitted. Doing so can cause damage to the seat and/or personal injury.

- Do not adjust the seat to a position where it can contact other components in the cab. Make sure that the seat is able to oscillate in any direction freely. Otherwise damage could occur to the seat or cab.
- Do not block any mechanisms with foreign objects, like for example bags and boxes.
- In order to prevent objects from flying and causing bodily injuries in situations such as sudden braking, do not place anything on the seat.
- The seat is designed to hold a maximum driver's weight of 330 lbs.

Information for visiting a workshop, repairs, maintenance and service

- In the case of seat failure or defective parts, an authorized workshop must be immediately visited so the seat can be repaired or exchanged.
- All seat functions have to be routinely checked, according to the appropriate maintenance intervals of the vehicle. At that time seat anchorages and fasteners, like screws, have to be checked for proper tightness. Locking mechanisms of horizontal slides, backrest recliner, tilt and seat cushion adjustment must be checked frequently for tightness as well, and to ensure that complete locking occurs in all positions.
- Inappropriate repairs or services can increase the risk of damaging the seat and the risk of injury. Therefore, modifications to the seat are not allowed.
- Only original spare parts can be used.
- In the case of a vehicle accident, the seat must be completely replaced.
- Welding of broken steel parts is not permitted.
- For running surfaces of the rollers no servicing is required. Rollers must not be oiled or greased.

Care Guidelines

- Since dirt can cause seat malfunctions, the seat must be routinely cleaned to ensure a long lifetime.
- Upholstery shall be vacuum cleaned.
- When cleaning the seat use a slightly damp cloth, without any strong cleaning products, for they could damage the seat. Before using any type of cleaning product, make sure to test it on a small patch that is not visible.
- Never soak the seat or use a hose when cleaning. Liquid on or inside of the seat can cause damage.

⚠ For your safety, and for the safety of other drivers, the seat can only be adjusted while seated and when the vehicle is fully stopped and the hand brake is pulled.

Before you start driving, the seat must be adjusted to an optimal position for your body and the correct seating posture must be taken, particularly when switching vehicles. Attention to detail is imperative to adjust the seat to an optimal position for your body. An incorrectly set seat or a wrong seating posture may have a negative impact on the ergonomics, driver's body, and operating capacity of the vehicle. Improper settings of the seat may effect the ability to properly operate the vehicle in a safe manner to prevent accidents which may cause serious or fatal accidents. Having a correct seating posture will enable the drivers to feel fit and comfortable during long roads.

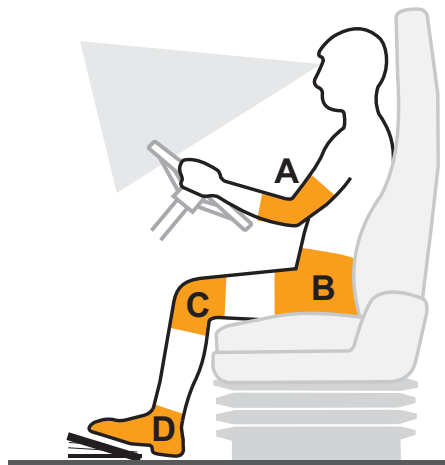

Optimal position for your body

- A** Angle of elbow joints 95° to 135°
- B** Angle of hip joint 100° to 115°
- C** Angle of knee joint 110° to 120°
- D** Angle of feet joint 90°

View of vehicle and instruments shall be clear.

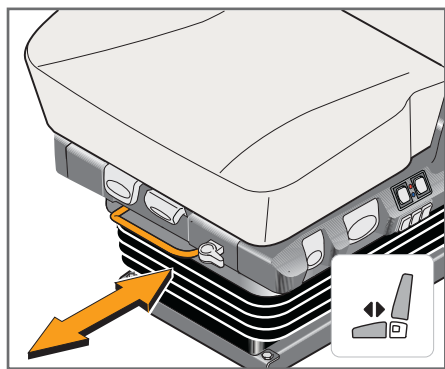

1 Horizontal Slides - Basic, Premium, Elite

This enables the drivers to perform their job in a comfortable position. It provides a better view and easier accessibility of the dashboard.

Pull the lever completely and move seat forwards/backwards. Once you have found your desired position, release the lever to lock the seat in place.

⚠ Make sure that you are adjusting the horizontal slides to a position where reaching and pressing the pedals requires no effort. Do not put your feet on the slide handle.

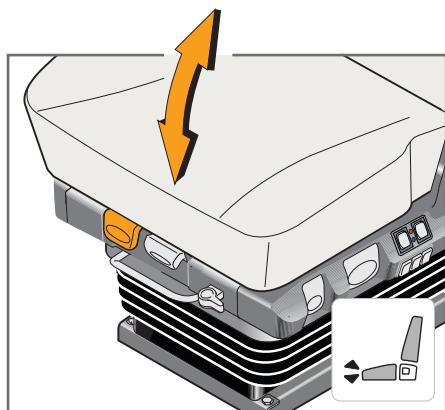

2 Tilt Adjustment - Basic, Premium, Elite

Enables the driver to reduce the load on the underside of the thighs and the back. The load depends on the inclination of seat and backrest and the contour of the cushion.

Pull lever and adjust the tilt by loading/unloading the front seat cushion area.

 For your safety, and for the safety of other drivers, the seat can only be adjusted while seated and when the vehicle is fully stopped and the hand brake is pulled.

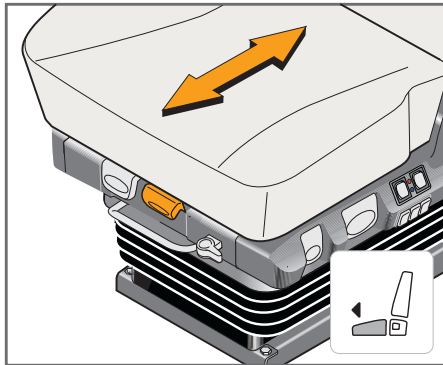

3 Seat Cushion Adjustment - Basic, Premium, Elite

Enables the driver to adapt the length of the cushion to the length of their thighs.

It helps to keep the feet and lower legs from "falling asleep" and provides a safer and more fatigue-proof posture.

Adjust the cushion so that 3 fingers fit in between the cushion's front edge and behind the operator's knee.

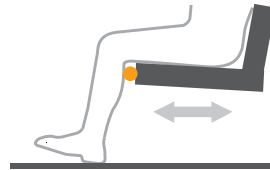

Pull the lever and move the seat cushion forward/backward. Release the lever to lock the seat.

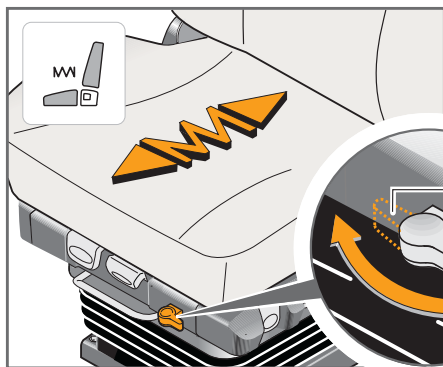

4 Horizontal Isolator - Basic, Premium, Elite

For damping horizontal shocks during off-road driving or while pulling a trailer, particularly with liquids.

Lever to the right:
Horizontal isolator released

Lever to the left:
Horizontal isolator blocked

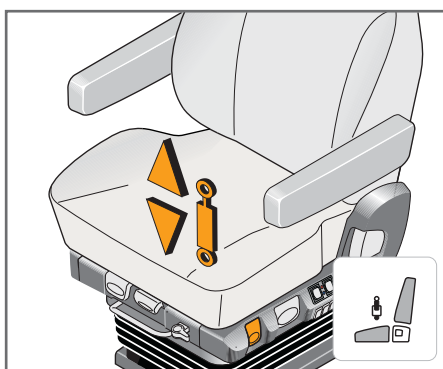

5 Damper Adjustment - Premium, Elite

Protects the spine of the driver, as the damper absorbs the vertical shocks and vibrations.

By adjusting the damper, the suspension characteristics of the seat can be optimally adapted to every roadway and every driver.

Lever up: Soft suspension - minimum damper force for flat roads.

Lever down: Hard suspension - maximum damper force for rough roads.

Damper adjustment must be adapted in the case of changing road conditions.

 The damper shall be adjusted stiff enough, so in rough road conditions the driver's feet never lose contact with the pedals. Don't adjust the damper so soft that on rough roads the seat can knock through. In general, heavy drivers don't have to use a soft adjusted damper.

⚠ For your safety, and for the safety of other drivers, the seat can only be adjusted while seated and when the vehicle is fully stopped and the hand brake is pulled.



6 Height Adjustment - Basic, Premium, Elite

It supports the driver so that the pedals can be reached comfortably by the feet and passed through all the way without force.

- Pedals must be actuated without stretching the legs completely.
- View of vehicle and instruments shall be clear.

Pull or push handle and adjust the seat to desired height.

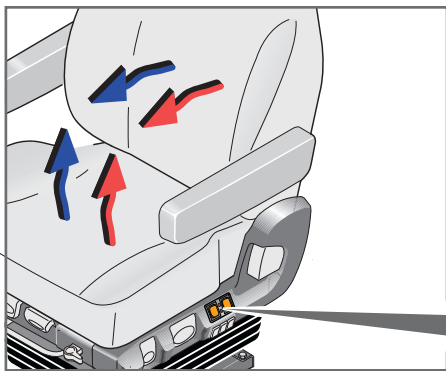

7 Heating and Ventilation System - Elite

8 Advanced cooling system to regulate the body temperature.

Avoid temperature-induced tension and fatigue by adjusting the temperature to your personal preference (in a close body region/ microclimate area).

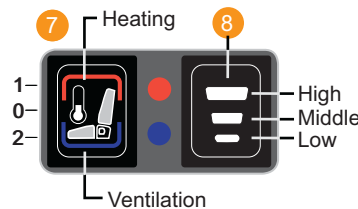

7 Switch to preselect heating or ventilation.

Middle (0) : Off: Heater and ventilation switched off.
 Up (1) : Heater switched on (red light).
 Down (2) : Ventilation switched on (blue light).

8 Level-switch to adjust the power of heating or ventilation.
 Press switch to adjust heater or ventilation in 3 steps from low to high.

⚠ The ventilation doesn't switch off automatically.
 In order to avoid under cooling of the body, the ventilation system should not work in continuous operation.
 Misuse of the seat heating system can lead to overheating or damage to the seat. This can include a wrong connection or using the seat for purposes it was not designed for, such as drying of wet clothes.
 Do not place anything - like for example jackets, blankets, pillows or bags - over the seat. It is also not allowed to use protective covers.
 It is not permitted to have the heater on while the seat is unoccupied.
 It is the driver's responsibility to make sure that the passenger seat heater is set to off when empty.

 For your safety, and for the safety of other drivers, the seat can only be adjusted while seated and when the vehicle is fully stopped and the hand brake is pulled.

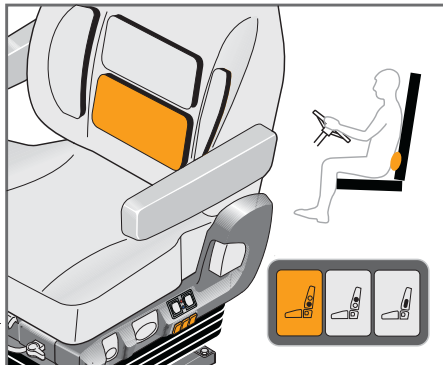

9 Lower Lumbar Support - Basic, Premium, Elite

Promotes an upright posture and prevents fatigue by tuning the backrest contour. This modified shape of the lower backrest adjusts the position of the driver's pelvis: This is achieved by turning the pelvis position and upright.

- Relaxation of muscles
- Load relief in the spine
- Increase in comfort

Press the button in the appropriate direction in order to support the pelvis in its forward position. This turns your spine into its ideal double S-shape.

The lumbar support prevents driving in a slouched, hunched or in a hollow-back position.

Please note that your whole back must touch the backrest from the buttocks to the shoulders. It is recommended to change the sitting position from time to time.

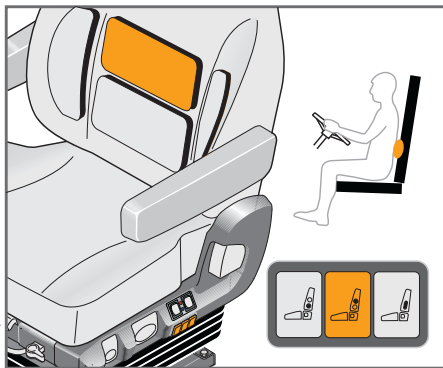

10 Upper Lumbar Support - Premium, Elite

Promotes an upright posture and prevents fatigue by tuning the backrest contour. This modified shape of the lower backrest compensates driver's hollow back.

- Relaxation of muscles
- Load relief in the spine
- Increase in comfort

Press the button in the appropriate direction to match the shape of the lower backrest contour in order to support the driver's back.

The lumbar support prevents driving in a slouched, hunched or in a hollow-back position.

Please note that your whole back must touch the backrest from the buttocks to the shoulders. It is recommended to change the sitting position from time to time.

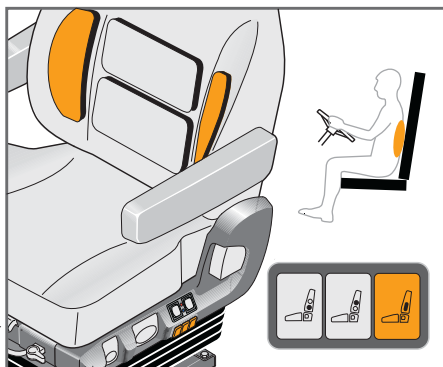

11 Side Bolster Support - Elite

Promotes an upright posture and prevents fatigue by tuning the backrest's side contour. It prevents the back from sliding continuously across the backrest from side to side.

- Relaxation of muscles
- Load relief in the spine
- Increase in comfort

The side bolsters of the backrest can be adjusted optimal to the driver's back width by blowing up or exhausting the air chambers.

The side bolster support prevents driving in a slouched position. It is recommended to change the sitting position from time to time.

⚠ For your safety, and for the safety of other drivers, the seat can only be adjusted while seated and when the vehicle is fully stopped and the hand brake is pulled.



12 Backrest Adjustment - Basic, Premium, Elite

Enables the driver to stay in a comfortable position for a longer period of time by providing a custom inclination of the backrest. An upright position avoids postures with a high load on the back.

Pull handle completely over the full adjustment stroke and adjust the backrest position by applying your back towards the backrest.

⚠ Don't adjust the backrest too far backwards when driving - this also applies to the passenger - in order to avoid the risk of sliding out of the belt during a full brake situation. Don't fold the backrest completely down to the seat cushion, in order to preserve the backrest's side bolsters.

Adjust the backrest to an inclination where the steering wheel can be reached with angled arms.

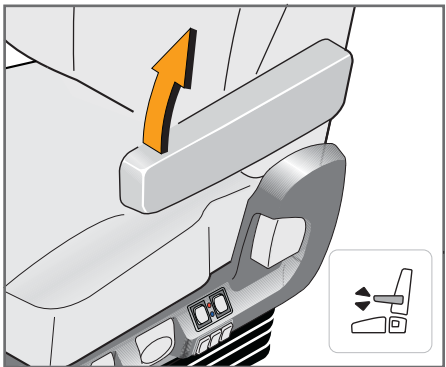

13 Armrest - Basic, Premium, Elite

Optimal adjustment of the armrests to relieve muscles in the spine and back.

- Enables relaxation of muscles in shoulder and neck area.
- Reduces the load on the spinal disc in the lower spine area.
- Adjust the armrest to a position where the elbows lay lightly on it.

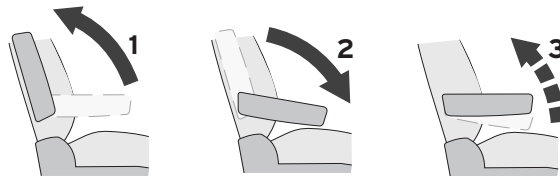

Fold up armrest (1) till final stop.
Then fold down armrest completely (2).
Now tilt up inclination to the desired height (3).

⚠ The armrest shall not be used as a method of ascent while entering the vehicle.

ISRINGHAUSEN INC.
1458 South 35th Street
Galesburg, MI 49053

E-Mail sales@isriusa.com
www.isriusa.com