

Seats for Special Vehicles
and Construction Vehicles



ISRI 6830 KM/855 NTS Compact

The innovative seat concept

The NTS Compact is the seat for compact and medium class vehicles with the proven ISRI NTS air suspension technology.



Seating – on a higher level.



NTS Compact

ISRI 6830KM/855 NTS

ISRI 6830KM/870 NTS

Construction vehicle version
ID Number: 813181-01

Communal vehicle version
ID Number: 813376-01

Agricultural machine version
ID Number: 813201-21



Applications

Agricultural and forestry wheeled tractors of category A, classes I, II and III, communal and construction vehicles.

Standards

- ISO 5353
- ISO 7096-2000
- 78/764 EWG Class I, II, III
- ISO 6683
- ECE R14 N2
- SAE J 386 / SAE J 2292
- FMVSS 302

SI point, low design

Vibration of the machine operator, EM 1, 3-6, 8 and 9

Directive for tractor seats

Earth moving machines, seat belts and anchorings

Belt anchorage points (only in combination with vehicle inspection)

Belt, US standard

Flame resistance

Information concerning the seat

ID Number: 813181-01 (2-point belt)

ID Number: 813376-01 (3-point belt)

ID Number: 813201-21 (with additional air tank)

Standard upholstery: textile fabric

Logo is optional and can be stamped or embroidered.

Seat program

| Equipment | 813181-01 | 813376-01 | 813201-21 |
|---|-----------|-------------|-----------|
| Weight adjustment (manually) | ● | ● | ● |
| Height adjustment | ● | ● | ● |
| Tilt adjustment | ● | ● | ● |
| Length adjustment | ● | ● | ● |
| Backrest adjustment | ● | ● | ● |
| Foldable backrest | ● | ● | ● |
| Backrest height (approx. in mm) | 554 | 815 | 815 |
| Belt fixing points (ECE R14) | ● | ● | ● |
| Seat cushion adjustment | ● | ● | ● |
| Pneumatic lumbar support (LWS) | ● | ● | -- |
| Pneumatic lumbar support and side bolster support (IPS) | -- | -- | ● |
| Track dimension | 320 | 320 | 216 |
| Foldable and tilting armrests | ○ | ● left-hand | ○ |
| Headrest | | ● | ● |
| Belt system | 2-point | 3-point | 3-point |
| Mechanical suspension | -- | -- | -- |
| Air suspension (compressor 12 V) | ● | ● | ● |
| Seat heating 12 V | ○ | ● | ● |

● Standard equipment

○ Option

Product advantages

- Compact design
- Perfected seat ergonomics
- Reasonable arrangement of the operating elements
- High lateral and longitudinal stiffness
- Low lateral and longitudinal clearance of the seat

Seats for Special Vehicles and Construction Vehicles

ISRI 6830 KM/855 NTS Compact

Subject to technical modifications.
Updated 01/2013

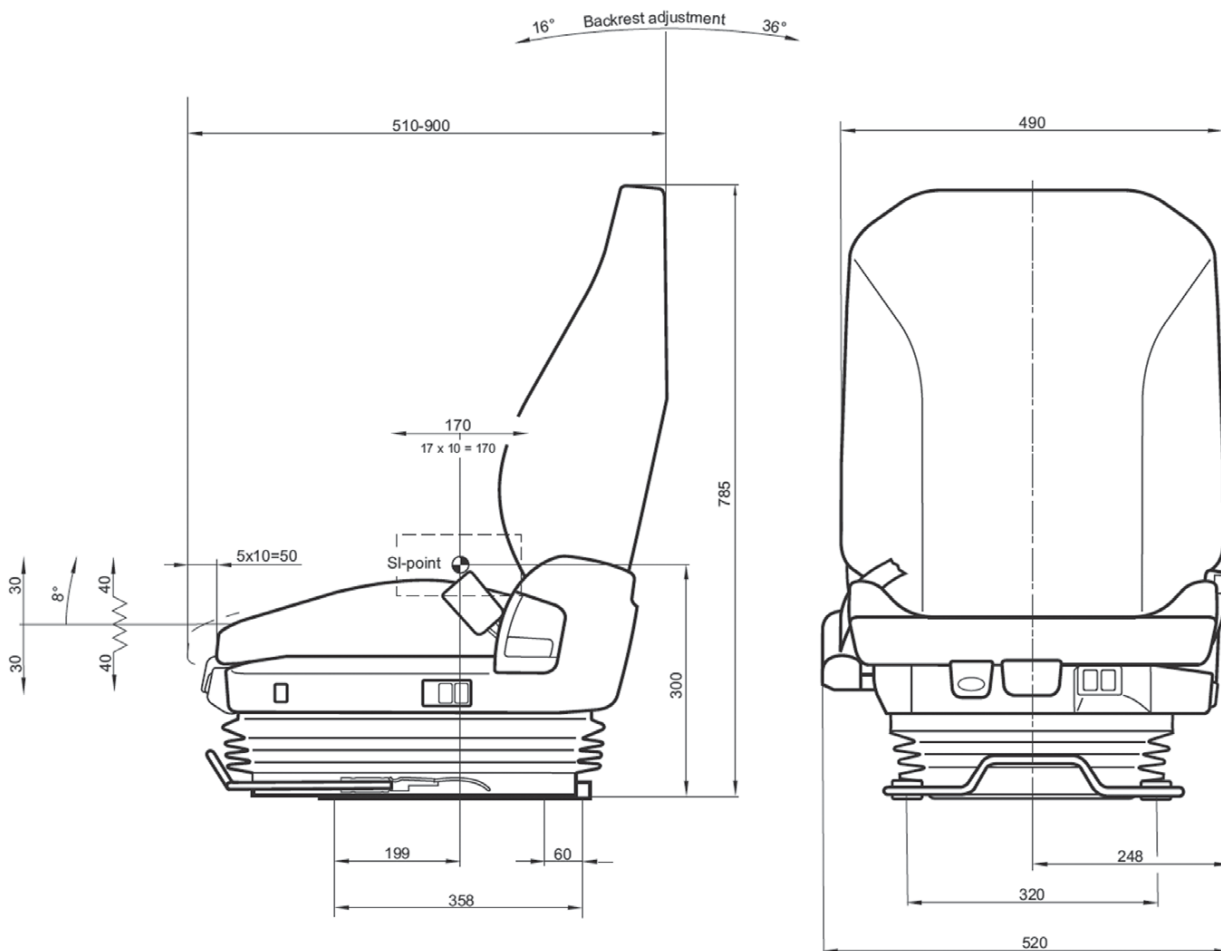

ISRINGHAUSEN Inc.
4269 Crosspoint Dr. Unit U
Ladson, SC 29456
USA
Phone: 833-249-5061 (Inside US)
843-225-1551 (Worldwide)

