

Seats for construction vehicles



ISRI® 6030/ 880 NTS

Driver's seat with mechanical suspension

If you've got something heavy to move, you need the right support: ISRI seats for construction vehicles

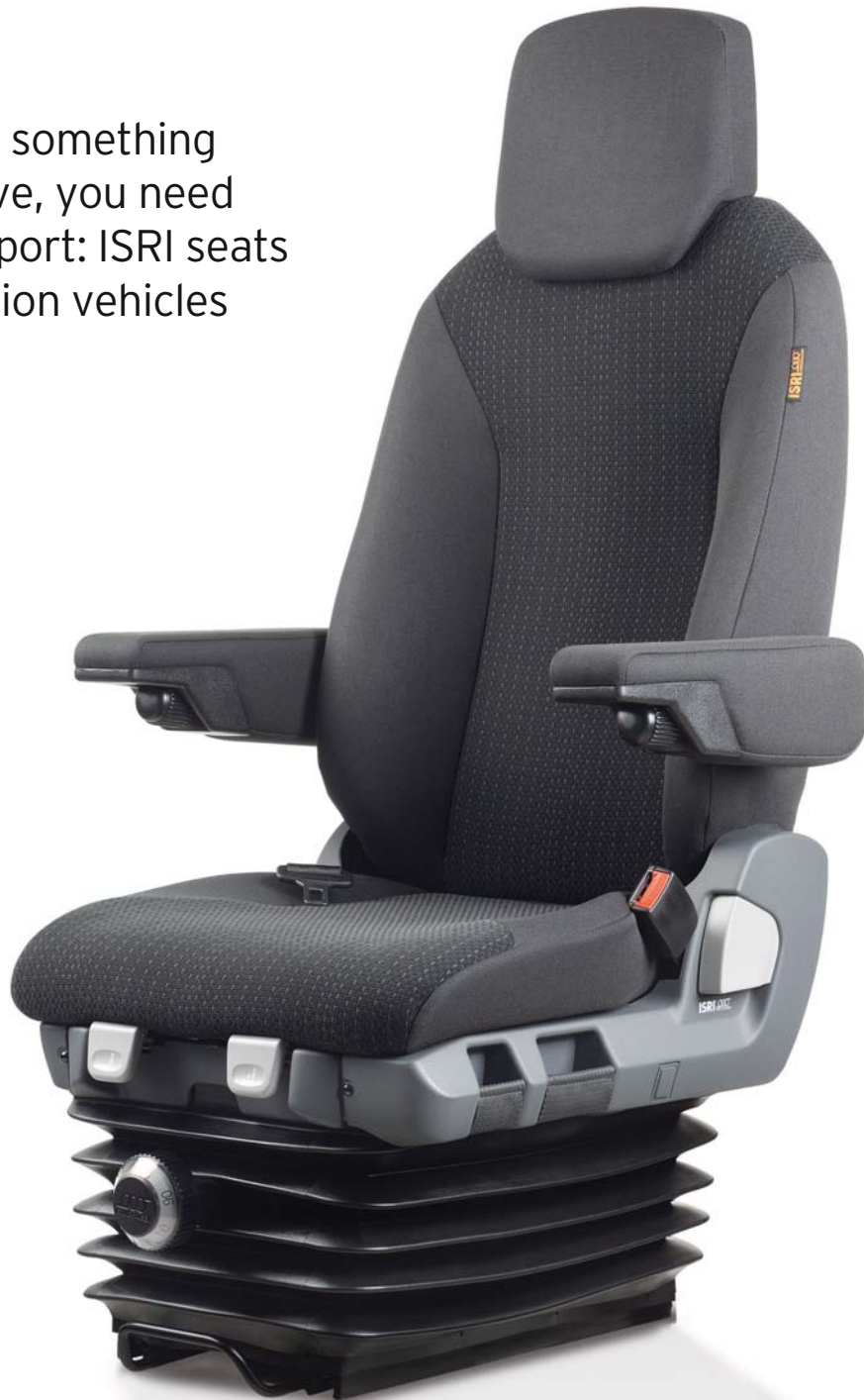

Seating – on a higher level.



ISRI® 6030/ 880 NTS

Our comfortable driver's seat for construction vehicles is exceptionally well made and extremely tough. The mechanical suspension is available in various versions to suit different vehicles, all of which conform to EN/ISO 7096:2000. The seat can be adjusted as required and comes with height and tilt adjustment as standard. Together with the automatically shaped seat and

backrest, these features take the tired-ness out of driving. The high-quality cover material is very hard-wearing.



Seat controls

Height and tilt adjustment, back

Height and tilt adjustment, front

Mechanical weight adjustment

Horizontal adjustment

Specifications

- Horizontal adjustment, lockable on both sides, 200mm
- Continuous weight adjustment up to 150 kg
- Suspension travel, 80 mm
- Fine height and tilt adjustment, up to 65 mm
- Two seat belt points in line with current regulations
- Hard-wearing, breathable textile cover

Options

- Armrests, folding and tilt-adjustable
- Seat heating, 12/24 V with on/off switch
- Adjustable lumbar support
- Automatic lap belt
- Safety headrests, height and tilt-adjustable
- Vinyl cover
- Swivel
- Adaption for control consoles

Armrest adjustment

Backrest adjustment



Seats for construction vehicles

ISRI® 6030/ 880 NTS

Driver's seat with mechanical suspension

For various current construction vehicle models.

Subject to technical modifications

Updated 02/2010

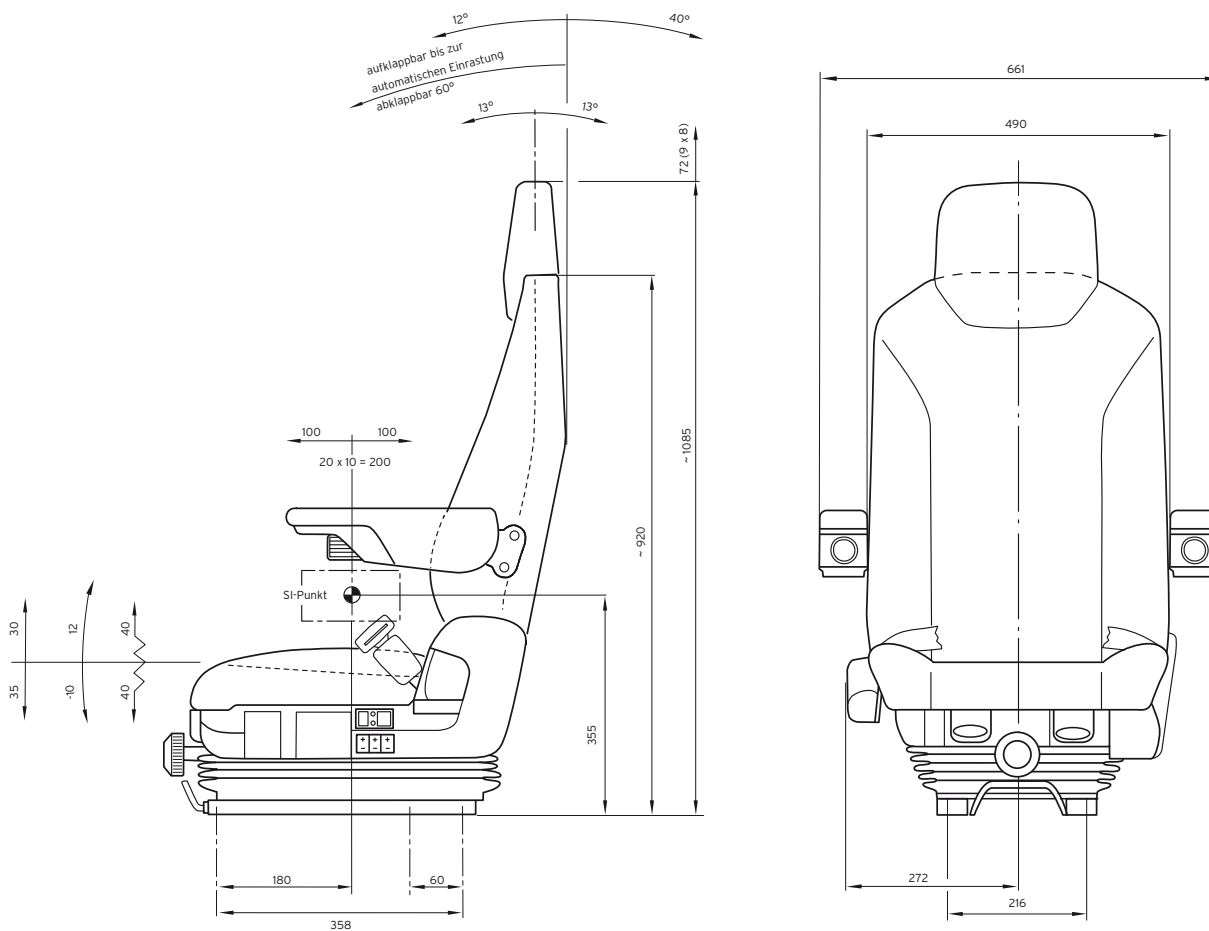

ISRINGHAUSEN, Inc.
1458 South 35th Street
Galesburg, Michigan 49053
USA
Fon (001) 2694845333; Fax (001) 2694845344
www.isriusa.com

